

An Introduction to Weld Probes

WHAT ARE WELD PROBES?

Weld Probes are specifically designed for the task of weld inspection of non-ferrous welds and steel structures. They can detect surface cracks on a weld with a non-conductive surface coating on it of up to 2mm.

The application specific design of the probe means that it is capable of inspecting welds with uneven surfaces and coatings on them.

PROBE ANATOMY

A probe was built with two orthogonal interleaved coils. The coils positioning is critical to producing signals as required in the inspection procedure.

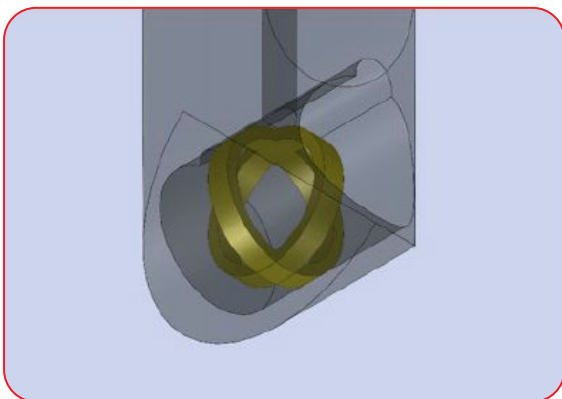

WHY USE EDDY CURRENT WELD PROBES FOR WELD INSPECTION?

Welds are often coated or painted making access to the weld for inspection more complicated when using other methods to Eddy Current. For example, MPI and UV inspection require the removing of the coating before inspection, costing both money and time. Eddy current probes allow welds to be efficiently inspected for near-surface cracks because the weld can be inspected through paint or metallic coatings.

SO WHY USE A SPECIAL WELD PROBE?

Firstly, by using a differential coil configuration, Eddy Current Weld Probes allow inspection without the need to remove any coating / paint.

Also Weld Probes are very sensitive to lift-off and variations in material properties caused by the heat affected zone through a simple absolute probe offering Low lift-off sensitivity variation; 8 db per mm as compared with the pencil probe at 40 db per mm. This gives minimal spurious signals caused by lift-off because of differential connection.

Benefits of using an Eddy Current Weld Probe.

- AN APPROVED METHOD TO REPLACE MPI.
- HAS APPROVAL FROM MANY CERTIFYING AUTHORITIES AND MANY TRAINING FACILITIES.
- A GOOD OPTION FOR ROPE ACCESS INSPECTORS - NO NEED FOR HIGH COST SCAFFOLDING ALSO.
- CAN DETECT CRACKS THROUGH SURFACE COATINGS.
- APPLICATION SPECIFIC DESIGN TO SUIT THE CLIENTS NEEDS.
- COST EFFECTIVE.
- TIME EFFICIENT.

APPLICATIONS

OFFSHORE

Widely used for Weld Inspection, replacing MPI due to not needing to remove surface coatings.

Ideal for Rope Access inspection needs.

RAIL

Used in the manual inspection of defects in rails and wheels.

Axle Inspection evidence shows greater reliability than UT.

Weld inspection on chassis and bogeys.

NUCLEAR

Widely used in the Nuclear NDT industry.

CONVENTIONAL MANUAL INSPECTION AND WITH AUTOMATED SCANNERS.

- Bridges
- Steel Framed Buildings
- Prison Bars detecting saw cuts.
- Overhead Traffic Lights
- Amusement Rides

THE WELD PROBE INSPECTION PROCEDURE

The inspection procedure requires a certain workflow of scanning. It is also important to remember that the active part of the probe is 3mm x 3mm. The diagrams below demonstrate this procedure:

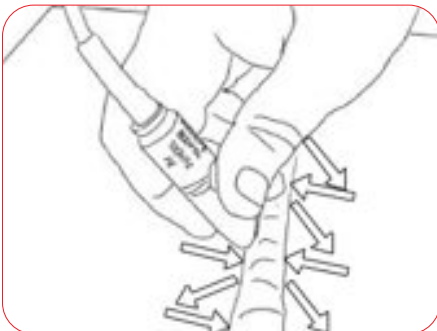

1. Zig-zag scan of the toe in the 'HAZ' (Heat Affected Zone) along the length of the Toe.

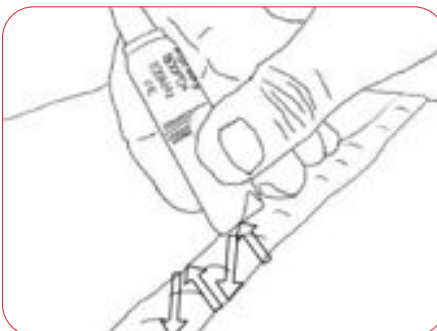

2. Scan of the Weld Cap.



3. A sweep along the Toe.

EQUIPMENT NEEDED TO PERFORM A WELD PROBE INSPECTION

ETher NDE can offer the full range of equipment needed to perform a Weld Probe Inspection.

An inspector will need:

- Impedance plane display eddy current instrument (e.g. VANTAGE or VERITOR).
- Weld probe.
- Paint probe to assess coating thickness and compensate calibration by means of shims.
- Test block with 2, 1 and 0.5Mm notches and four 0.5Mm shims.
- A full datasheet complete with all the options for *ETHer NDE* Weld Probes is available. *ETHer NDE* will also be happy to help with any application specific Weld Probe design.



WELD PROBES: BRIDGE

Benefits

- Broad frequency range.
- Cables up to 50 metres available.
- Able to detect cracks through a wide range of coatings.
- Available in a wide range of diameters.

Applications

Differential Weld probes ideal for in-service inspection of welded structures.

The following range of *ETHER NDE* Weld Probes is available in a number of different sizes and frequencies, all with minimal lift-off signal. They can detect surface breaking fatigue cracks through 2mm of surface coating material and are therefore less expensive and quicker to use than other techniques.

Bridge Weld Probes offer many Key Features within their specification including:

- Straight, 90° Inline, 90° Right Angle
- Diameters, 11.0mm (Small), 16mm (Medium), 32mm (Large)
- Dis-connectable and integral probe cables
- Cable lengths from 1.5 to 50 metres
- Frequency range 100, 20, 100-600kHz
- Minimal lift off signal, can find cracks through paint, oil and conductive and non-conductive coatings
- Made from hard wearing PET
- Stainless steel and ceramic tips available on request

Note:

- 100kHz probes used on standard ferrous welds
- 100-600kHz probe can be used on Aluminium and Stainless Steel welds
- 20kHz probe can be used on multi-surface applications.

STRAIGHT



90° INLINE

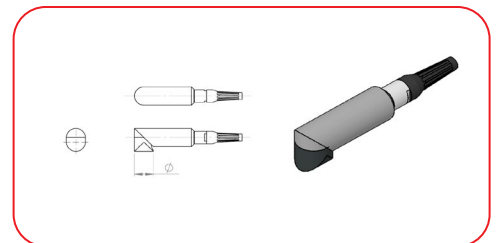

90 ° TRANSVERSE

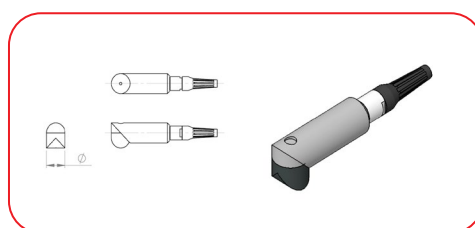

WATERPROOF



WELD PROBE (BRIDGE) CODING SYSTEM

PWS100S015L12

PW Probe Weld (Plastic)

S Dia 11.0mm (Small)

M Dia 16.0mm (Medium)

L Dia 32.0mm (Large)

100 100kHz (Standard)

020 20kHz Enhanced

106 100-600kHz Multi-surface

S Straight

I 90 deg Inline

R 90 deg Transverse

000 Disconnect

015 1.5m Cable

050 5.0m Cable

100 10.0m Cable

500 50.0m Cable

L7 7 Way Lemo

L12 12 Way Lemo

J6 6 Way Jaeger

A4 4-way Amphenol

C3 3-way Cannon

W Waterproof

Example: PWS100S015L12

Part Number: Probe, Weld, Dia. 11.0mm (Small), 100kHz, Straight,
1.5m Cable, Lemo 12-Way.

Other options are available so please feel free to contact us directly.

STRAIGHT WELD PROBE: BRIDGE

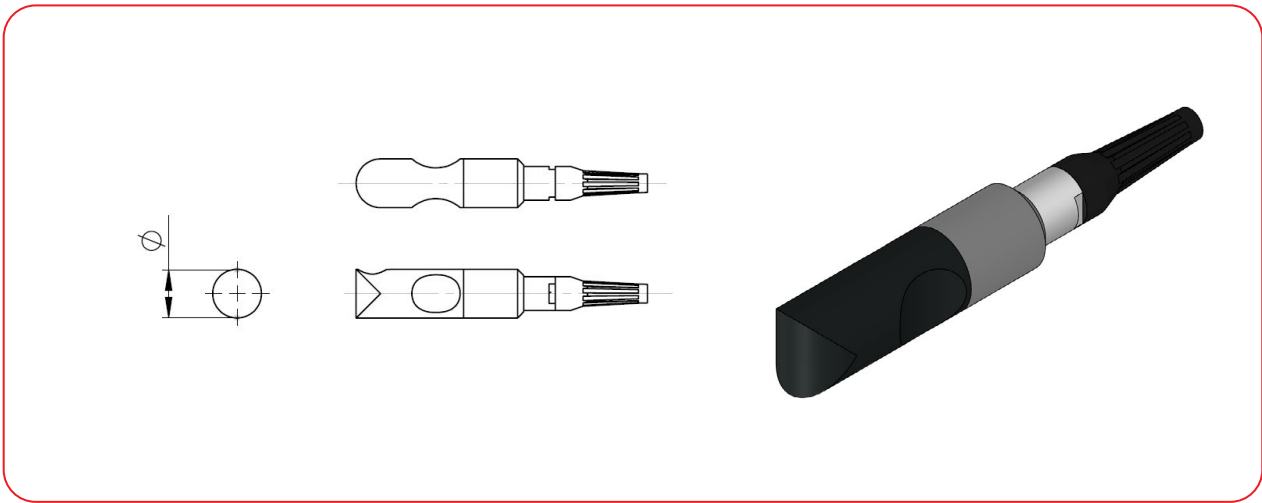

ETHer Part No	Hocking Part No	Frequency	Description
PWS100S015L12	800P01MB1P	100kHz	Probe, Weld, Small, Dia 11.00, 100kHz, Straight, 1.5m Cable, Lemo 12-Way
PWS100S015L7	800P01NB1P	100kHz	Probe, Weld, Small, Dia 11.00, 100kHz, Straight, 1.5m Cable, Lemo 7-Way
PWS100S015J6	800P01JB1P	100kHz	Probe, Weld, Small, Dia 11.00, 100kHz, Straight, 1.5m Cable, Jaeger 6-Way
PWM100S015L12	800P04MB1P	100kHz	Probe, Weld, Medium, Dia 16.00, 100kHz, Straight, 1.5m Cable, Lemo 12-Way
PWM100S015L7	800P04NB1P	100kHz	Probe, Weld, Medium, Dia 16.00, 100kHz, Straight, 1.5m Cable, Lemo 7-Way
PWM100S015J6	800P04JB1P	100kHz	Probe, Weld, Medium, Dia 16.00, 100kHz, Straight, 1.5m Cable, Jaeger 6-Way
PWL100S015L12	800P06MB1P	100kHz	Probe, Weld, Large, Dia 32.00, 100kHz, Straight, 1.5m Cable, Lemo 12-Way
PWL100S015L7	800P06NB1P	100kHz	Probe, Weld, Large, Dia 32.00, 100kHz, Straight, 1.5m Cable, Lemo 7-Way
PWL100S015J6	800P06JB1P	100kHz	Probe, Weld, Large, Dia 32.00, 100kHz, Straight, 1.5m Cable, Jaeger 6-Way
PWS100S050L12	800P01MD1P	100kHz	Probe, Weld, Small, Dia 11.00, 100kHz, Straight, 5.0m Cable, Lemo 12-Way
PWS100S050L7	800P01ND1P	100kHz	Probe, Weld, Small, Dia 11.00, 100kHz, Straight, 5.0m Cable, Lemo 7-Way
PWS100S050J6	800P01JD1P	100kHz	Probe, Weld, Small, Dia 11.00, 100kHz, Straight, 5.0m Cable, Jaeger 6-Way
PWM100S050L12	800P04MD1P	100kHz	Probe, Weld, Medium, Dia 16.00, 100kHz, Straight, 5.0m Cable, Lemo 12-Way
PWM100S050L7	800P04ND1P	100kHz	Probe, Weld, Medium, Dia 16.00, 100kHz, Straight, 5.0m Cable, Lemo 7-Way
PWM100S050J6	800P04JD1P	100kHz	Probe, Weld, Medium, Dia 16.00, 100kHz, Straight, 5.0m Cable, Jaeger 6-Way
PWL100S050L12	800P06MD1P	100kHz	Probe, Weld, Large, Dia 32.00, 100kHz, Straight, 5.0m Cable, Lemo 12-Way
PWL100S050L7	800P06ND1P	100kHz	Probe, Weld, Large, Dia 32.00, 100kHz, Straight, 5.0m Cable, Lemo 7-Way
PWL100S050J6	800P06JD1P	100kHz	Probe, Weld, Large, Dia 32.00, 100kHz, Straight, 5.0m Cable, Jaeger 6-Way

90° INLINE WELD PROBE: BRIDGE

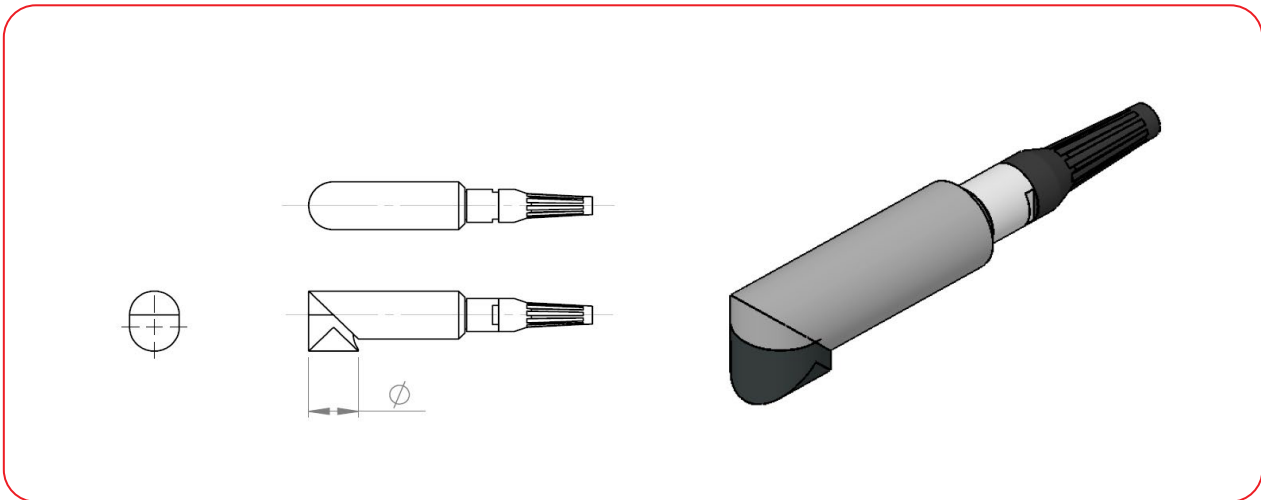

	Hocking Part No	Frequency	Description
PWS100I015L12	801P01MB1P	100kHz	Probe, Weld, Small, Dia 11.00, 100kHz, 90 deg Inline, 1.5m Cable, Lemo 12-Way
PWS100I015L7	801P01NB1P	100kHz	Probe, Weld, Small, Dia 11.00, 100kHz, 90 deg Inline, 1.5m Cable, Lemo 7-Way
PWS100I015J6	801P01JB1P	100kHz	Probe, Weld, Small, Dia 11.00, 100kHz, 90 deg Inline, 1.5m Cable, Jaeger 6-Way
PWM100I015L12	801P04MB1P	100kHz	Probe, Weld, Medium, Dia 16.00, 100kHz, 90 deg Inline, 1.5m Cable, Lemo 12-Way
PWM100I015L7	801P04NB1P	100kHz	Probe, Weld, Medium, Dia 16.00, 100kHz, 90 deg Inline, 1.5m Cable, Lemo 7-Way
PWM100I015J6	801P04JB1P	100kHz	Probe, Weld, Medium, Dia 16.00, 100kHz, 90 deg Inline, 1.5m Cable, Jaeger 6-Way
PWL100I015L12	801P06MB1P	100kHz	Probe, Weld, Large, Dia 32.00, 100kHz, 90 deg Inline, 1.5m Cable, Lemo 12-Way
PWL100I015L7	801P06NB1P	100kHz	Probe, Weld, Large, Dia 32.00, 100kHz, 90 deg Inline, 1.5m Cable, Lemo 7-Way
PWL100I015J6	801P06JB1P	100kHz	Probe, Weld, Large, Dia 32.00, 100kHz, 90 deg Inline, 1.5m Cable, Jaeger 6-Way
PWS100I050L12	801P01MD1P	100kHz	Probe, Weld, Small, Dia 11.00, 100kHz, 90 deg Inline, 5.0m Cable, Lemo 12-Way
PWS100I050L7	801P01ND1P	100kHz	Probe, Weld, Small, Dia 11.00, 100kHz, 90 deg Inline, 5.0m Cable, Lemo 7-Way
PWS100I050J6	801P01JD1P	100kHz	Probe, Weld, Small, Dia 11.00, 100kHz, 90 deg Inline, 5.0m Cable, Jaeger 6-Way
PWM100I050L12	801P04MD1P	100kHz	Probe, Weld, Medium, Dia 16.00, 100kHz, 90 deg Inline, 5.0m Cable, Lemo 12-Way
PWM100I050L7	801P04ND1P	100kHz	Probe, Weld, Medium, Dia 16.00, 100kHz, 90 deg Inline, 5.0m Cable, Lemo 7-Way
PWM100I050J6	801P04JD1P	100kHz	Probe, Weld, Medium, Dia 16.00, 100kHz, 90 deg Inline, 5.0m Cable, Jaeger 6-Way
PWL100I050L12	801P06MD1P	100kHz	Probe, Weld, Large, Dia 32.00, 100kHz, 90 deg Inline, 5.0m Cable, Lemo 12-Way
PWL100I050L7	801P06ND1P	100kHz	Probe, Weld, Large, Dia 32.00, 100kHz, 90 deg Inline, 5.0m Cable, Lemo 7-Way
PWL100I050J6	801P06JD1P	100kHz	Probe, Weld, Large, Dia 32.00, 100kHz, 90 deg Inline, 5.0m Cable, Jaeger 6-Way

90° TRANSVERSE WELD PROBE: BRIDGE

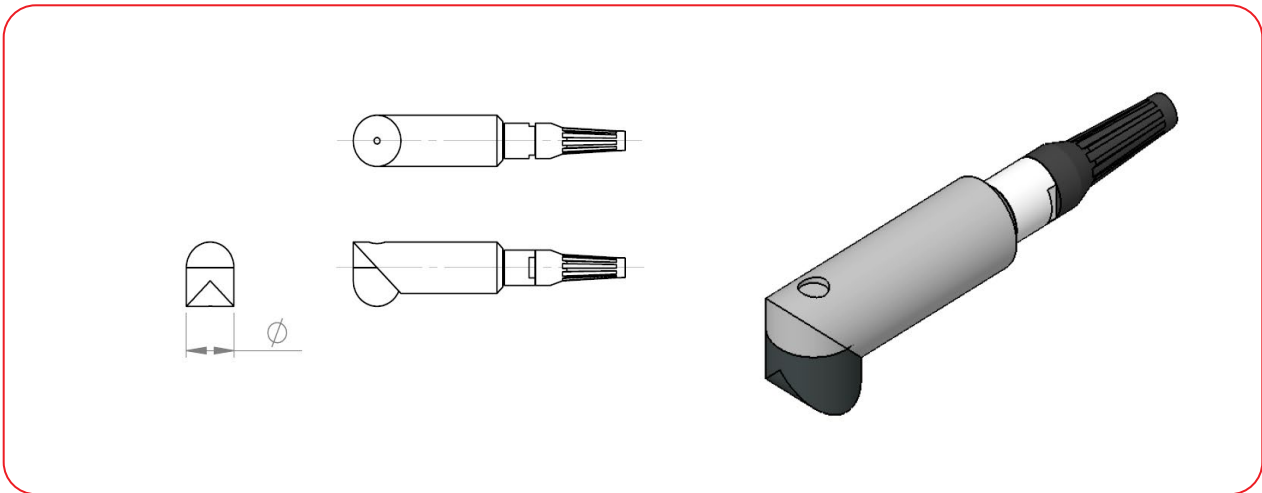

ETHer Part No	Hocking Part No	Frequency	Description
PWS100R015L12	802P01MB1P	100kHz	Probe, Weld, Small, Dia 11.00, 100kHz, 90 deg Right Angle, 1.5m Cable, Lemo 12-Way
PWS100R015L7	802P01NB1P	100kHz	Probe, Weld, Small, Dia 11.00, 100kHz, 90 deg Right Angle, 1.5m Cable, Lemo 7-Way
PWS100R015J6	802P01JB1P	100kHz	Probe, Weld, Small, Dia 11.00, 100kHz, 90 deg Right Angle, 1.5m Cable, Jaeger 6-Way
PWM100R015L12	802P04MB1P	100kHz	Probe, Weld, Medium, Dia 16.00, 100kHz, 90 deg Right Angle, 1.5m Cable, Lemo 12-Way
PWM100R015L7	802P04NB1P	100kHz	Probe, Weld, Medium, Dia 16.00, 100kHz, 90 deg Right Angle, 1.5m Cable, Lemo 7-Way
PWM100R015J6	802P04JB1P	100kHz	Probe, Weld, Medium, Dia 16.00, 100kHz, 90 deg Right Angle, 1.5m Cable, Jaeger 6-Way
PWL100R015L12	802P06MB1P	100kHz	Probe, Weld, Large, Dia 32.00, 100kHz, 90 deg Right Angle, 1.5m Cable, Lemo 12-Way
PWL100R015L7	802P06NB1P	100kHz	Probe, Weld, Large, Dia 32.00, 100kHz, 90 deg Right Angle, 1.5m Cable, Lemo 7-Way
PWL100R015J6	802P06JB1P	100kHz	Probe, Weld, Large, Dia 32.00, 100kHz, 90 deg Right Angle, 1.5m Cable, Jaeger 6-Way
PWS100R050L12	802P01MD1P	100kHz	Probe, Weld, Small, Dia 11.00, 100kHz, 90 deg Right Angle, 5.0m Cable, Lemo 12-Way
PWS100R050L7	802P01ND1P	100kHz	Probe, Weld, Small, Dia 11.00, 100kHz, 90 deg Right Angle, 5.0m Cable, Lemo 7-Way
PWS100R050J6	802P01JD1P	100kHz	Probe, Weld, Small, Dia 11.00, 100kHz, 90 deg Right Angle, 5.0m Cable, Jaeger 6-Way
PWM100R050L12	802P04MD1P	100kHz	Probe, Weld, Medium, Dia 16.00, 100kHz, 90 deg Right Angle, 5.0m Cable, Lemo 12-Way
PWM100R050L7	802P04ND1P	100kHz	Probe, Weld, Medium, Dia 16.00, 100kHz, 90 deg Right Angle, 5.0m Cable, Lemo 7-Way
PWM100R050J6	802P04JD1P	100kHz	Probe, Weld, Medium, Dia 16.00, 100kHz, 90 deg Right Angle, 5.0m Cable, Jaeger 6-Way
PWL100R050L12	802P06MD1P	100kHz	Probe, Weld, Large, Dia 32.00, 100kHz, 90 deg Right Angle, 5.0m Cable, Lemo 12-Way
PWL100R050L7	802P06ND1P	100kHz	Probe, Weld, Large, Dia 32.00, 100kHz, 90 deg Right Angle, 5.0m Cable, Lemo 7-Way
PWL100R050J6	802P06JD1P	100kHz	Probe, Weld, Large, Dia 32.00, 100kHz, 90 deg Right Angle, 5.0m Cable, Jaeger 6-Way



Document number 5009: Issue 2

ETHER NDE Ltd, 18 Brick Knoll Park, Ashley Road, St. Albans, Hertfordshire, AL1 5UG, UK.

tel: +44 (0) 1727 648050 email: sales@ethernde.com ethernde.com